



RAZORCENTRAL

Principles and practice of straight razor use and care

1. home
2. preface
3. razor parts
4. blade points
5. razor identification
6. the edge
7. grinds
8. grinds, why
9. sharpening introduction
10. stones
11. strops
12. using stones, introduction
13. blade - stone geometry
14. first stroke on stone
15. last stroke on stone
16. using the strop, introduction
17. first stroke on strop
18. last stroke on strop
19. preparation for shave
20. numbered shaving paths
21. face, right side
22. face, left side
23. chin
24. coup de maitre
25. throat
26. second over
27. preface to archives
28. La pogonotomia I
29. La pogonotomia II
30. La pogonotomia III
31. La pogonotomia IV
32. the razor I
33. the razor II
34. the razor III
35. the razor IV
36. the razor V
37. the razor VI
38. references
39. summary
40. guestbook

Preface

(PICTURE Missing)

Two centuries ago many people understood how to use and care for a straight razor, but most of the written information is lost now. Since the end of the eighteenth century, declining knowledge brought bad performance and the subsequent fall of the straight razor, a process still going on. Wrongly, because the efficacy of a well treated straight razor is unmatched by any comparable instrument.

This website is a reference that treats the original principles and practice of straight razor usage. Its purpose is to bring together science, skills, and the art of the craft, and to analyze the many opinions and habits, which are and have been the primary cause of failures. To put everything in perspective, I included abstracts of two historical books, which treated the pogonotomy in detail, and predicted why one of the most perfect tools in history would almost vanish more than two hundred years after publication.

I thank all contributors, specially Mrs. and Mr. Lorenzi for giving me the great book of Perret, *La Pogonotomia*, translated by Mrs. Lorenzi, Mr. Schremmel from DOVO Solingen and Mr. Morocutti from the Knife shop in Vienna for their instructions and the guided tours on location, Mr. Newson from Claremont, Australia for sending me valuable documentation and ideas, and last but not least the core of sincere contributors to rec.knives. Special thanks to Mr. Peter de Weijer from the Electric Shaver Museum in Amsterdam who sent me very valuable information, and who exploits an excellent site partially dealing with the subject. Further, very special thanks to Mr. David Loft, Mr. Gilles Reynewater, and Mr. Fayette, from Thiers-Issard, for the many hours they spent to demonstrate to me in detail the secrets of the square.

Razor parts

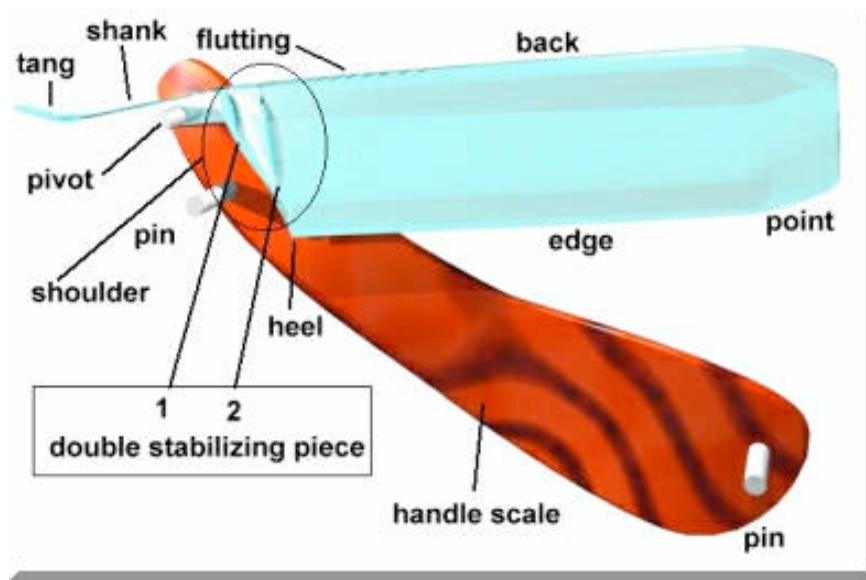

The straight razor consists of a handle and a blade. The handle consists of two shells, bridged by three pins. One of the pins is the pivot between the handle and the blade. The blade has an integrated tang. The transverse furrows on the top of the tang are called fluting or flutting and originally served to improve the grip. The blade and tang often contain engravings or etchings, indicating size and brand.

The stabilizing piece resists against torsion. It can be single, double, or single ellipsoid, depending on blade style, type, and esthetics.

Blades are made of normal steel with a carbon-content of 0.6% or more, and of rust-resistant chromium-steel. Carbon steel is easier to sharpen but more brittle, liable to chipping off and staining. Stain-resistant steel takes longer honing, but the results hold longer, and the edge is less vulnerable. Handles are made of Ambonia, Celluloid, Bone, Pakkawood, Mother of pearl, Ebony, Buffalo horn, Plastic. Celluloid is flammable and spontaneous inflammation has been described at higher natural temperatures. Even now, celluloid production is associated with extreme safety measures. Buffalo Horn can deform after some time, increasing the risk of edge damage when closing the knife: it has form memory, but for the wrong form. Mother of pearl is brittle, which might result in cracks soon. Plastic is very thin and easy to deform, causing increased risk that the edge touches the handle while closing it. The hardwood handles do not rot because they are highly impregnated with resins; the weight gives ideal balance. Bone is stable as well. Both packawood, snakewood, and bone have the best material properties for intensive use.

The razorblade must be guided while closing, because all handles may loose their form a little after some time, which is normal.

Points

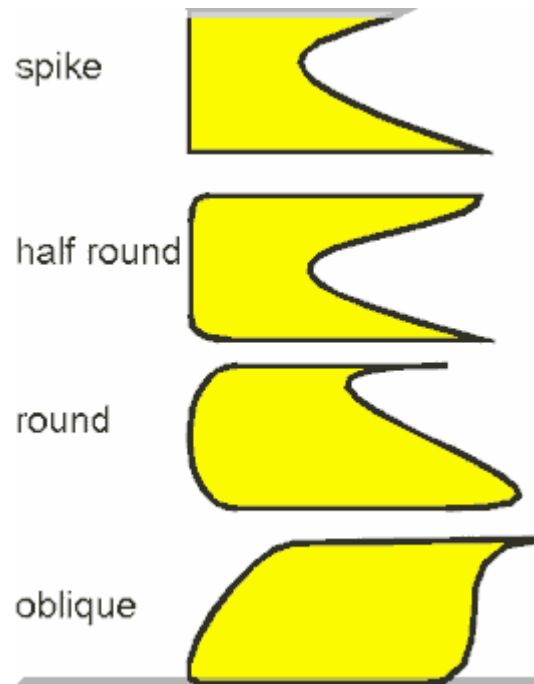

There are four main point styles. In theory, every grind may be associated with every style, although the oblique point is most often seen in straight grind razors.

The spike is for exact work in small area's. However, there is an increased risk of pinching the skin with the spike, and the other point styles suffice. Further, the choice of point style is a just a matter of esthetics and not of purpose.

The shape of the back is nowadays relatively constant and less relevant for the function of the razor. However, the back serves as a guide to keep a constant angle during honing and stropping. Therefore, the surface of the back must be polished and rounded where it gets into contact with the sharpening medium. There are four main point styles. In theory, every grind may be associated with every style, although the oblique point is most often seen in straight grind razors

Identification

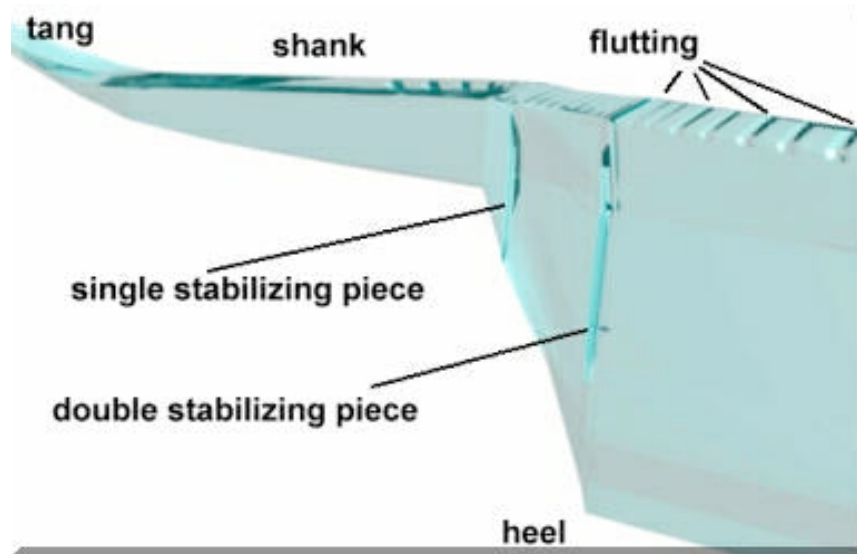

Identification marks are the width, the number of stabilizing pieces, and the reflection band. The double stabilizing piece indicates full hollow grind. A straight grind or non full hollow grind razor can be identified by its single straight stabilizing piece. Instead, the razor may have a single semicircular stabilizing piece, which we also only find in full hollow grind razors. The reflection band is caused by the diverging light rays on the convex surface of a ridge, which is the belly. This too is specific for full hollow grind razors.

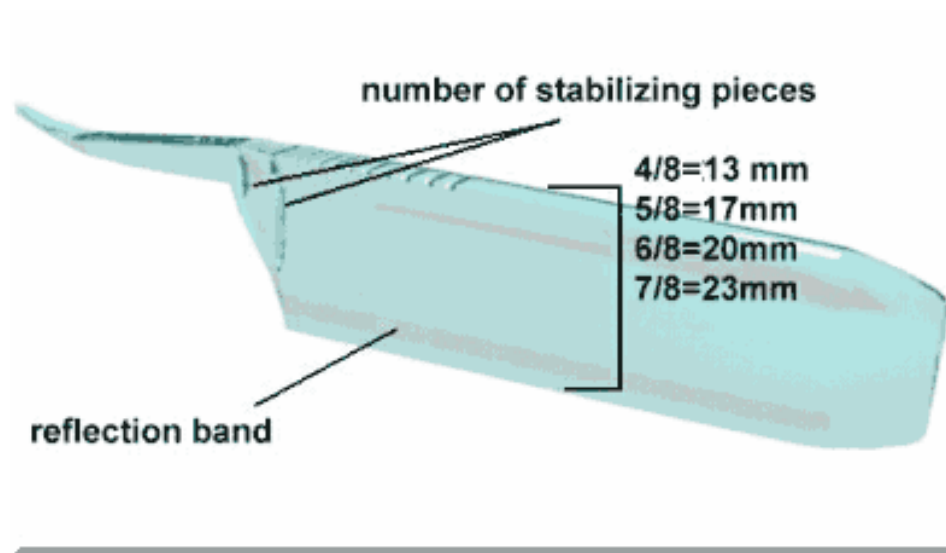

The edge

sharp & dull

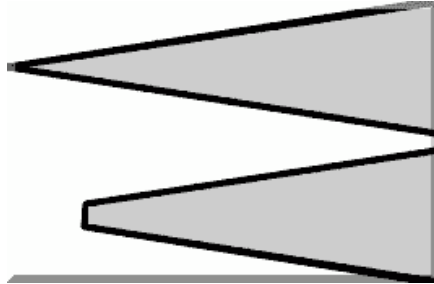

Sharpness and dullness are defined as the edge sides meeting at a single point and a surface, respectively. This scheme shows a sharp and a dull blade.

strength

An edge should not chip off during adequate usage. Thin, weak and small-angled edges can handle delicate objects. The razor's 15-20° edge is an ideal compromise between sharpness and strength.

serrations

Under the microscope, even a perfect edge looks serrated. A perfect smooth edge would be ideal because it would split the molecular bonding of the object. Serrations act like a saw. The purpose of razor sharpening is to create a smooth edge, and to take advantage of the inevitable serrations as much as possible.

burr



Sharpening approaches the sides of an edge, forming a ragged, rough edge which is so weak that it bends away from the sharpening medium, as the scheme shows. This so called burr feels sharp first, but it is thin and weak and will break away soon, exposing a dull surface. The burr is the signal that the two edge sides have joined. It can be a help when a lot of metal must be removed in wedge shaped blades; the second step is to remove the burr by honing at a greater

angle. However, relying on a burr to save effort is not necessary in the hollow grind razors. The sharpening of razors differs from sharpening knives in that burr formation should be avoided. It is difficult to measure and standardize sharpness. Electron microscopic studies (Lee) showed that with a #6000 waterstone and subsequent honing with chromium oxide, can make a chisel sharper than a Wilkinson Sword razor blade.

Grinds

(PICTURE Missing)

Grind is defined as the transectional geometry of a blade. Blades can be straight grind with a wedge shape, hollow grind with biconcave sides, or transitional grinds. Full hollow grind blades have a belly or ridge which gives the thin metal torsional resistance.

The terms 1/1 and 1/4 hollow grind indicate the degree of hollow grind, but also point to the parts of a full hollow grind blade below and above the belly. The former definition distinguishes different types of razor blades, the latter refers to the successive phases in the production process.

When the blade rests on a flat surface, the sides of a straight grind blade touch the surface. However, only the back and the edge of a hollow grind blade touch the surface. The belly never reaches the surface. These differences between straight- and hollow grind blades are essential for the process of sharpening.

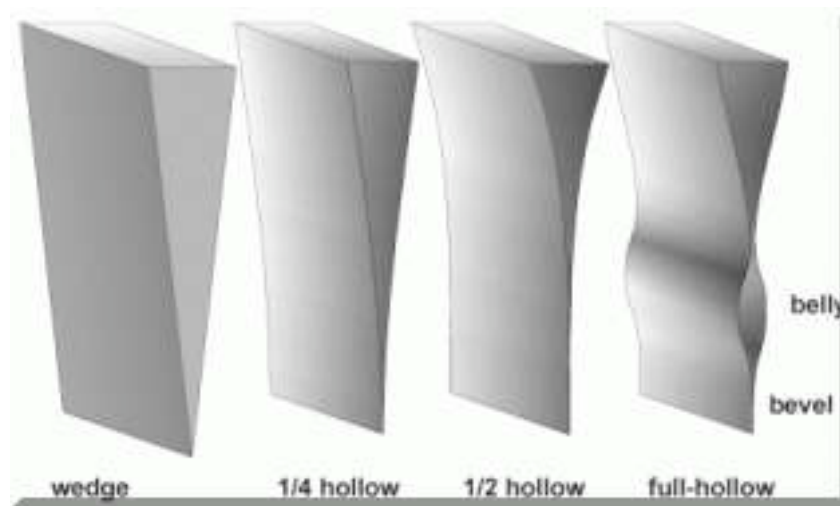

Grinds, why?

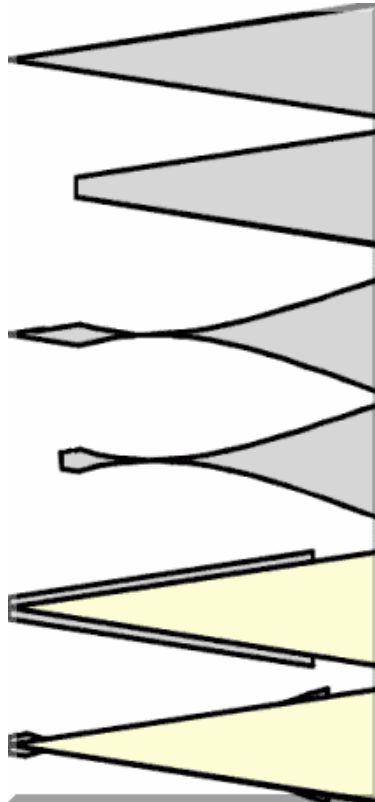

Sharpening restores the original edge angle. This scheme shows sharp and dull wedge shaped and hollow grind blades, and a yellow sjablone indicating the restored edge angle.

The dark parts exposed by the sjablone represent the volume of metal to be removed during sharpening. This is smaller with hollow grind than with wedge shaped blades. This proportion remains constant during the life of a razor. Therefore, client-level sharpening of hollow grind razors is easier and faster than of wedge shaped razors. Hollow grind razors are more expensive than wedge shaped razors, because the production process is more complex. However, the quality and the degree of sharpness are principally equal in both types. Only their purposes differ, which is treated in later chapters.

Hollow grinding reduces the real cutting angle. This reduction A compared with the straight edge angle B at a blade thickness X and a wheel diameter Y can be calculated as follows: $\sin A = X / (Y \times \sin B)$.

Introduction

All types of abrasion are principally identical except for the speed with which metal is removed. Grinding is creates the rough form, e.g. the grind type (hollow, full hollow, wedge) and is often done on a wheel. The ultimate cutting part is the delicate very narrow angled and hardly visible edge that must be set on a hone. When honing is done, the edge must be polished on a finer medium, e.g. a leather strop. The strop aligns the microserrations caused by the hone particles, and thus reduces the cutting surface in contact with the object.

Hair is protein and can be cut easily with the ideal edge that splits molecular bonding: small angle, weak, polished. This contrasts with stronger objects that easily damage an edge and which need saw like sharpness and thicker edges, a clear trade-off on ideal sharpness.

Sharpening a razor is a trick and a motor skill, comparable with many activities in daily life. Some basic techniques must be learned, which are described here. Literature is unclear about oils and stone choice, but the ideal set which is in accordance with concepts addressed in literature is the combination of a synthetic #8000 Japanese waterstone, the largest possible Juchten/canvas strop, the latter being treated with olive oil only - and never any pastes or soaps - two times a year.

This is a combination of a modern solution (the waterstone) with old official techniques. Many grand-mother tricks dating back from the beginning of the century are institutionalized confabulations due to lost knowledge; they are the major causes of failures. The natural stones quarried in the 18th century were superior to any natural stone produced after 1900; the ultra fine synthetic waterstone from Japan is an excellent or even better alternative.

Hones

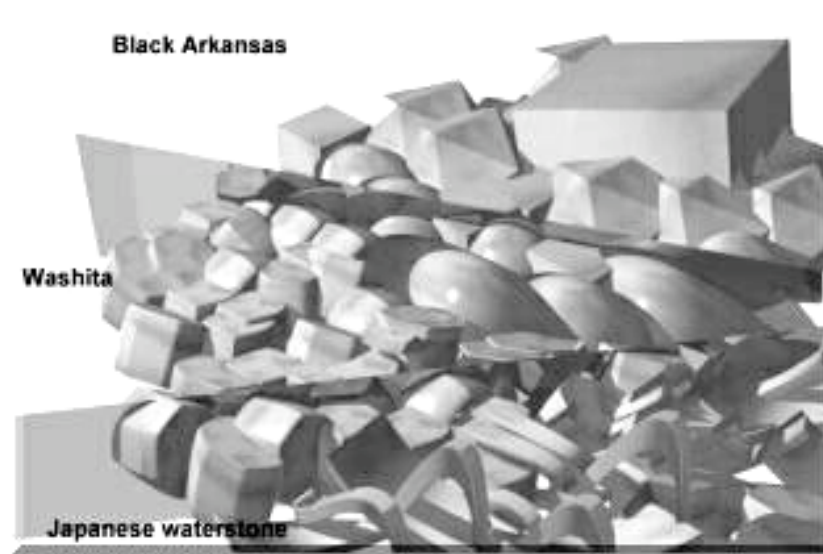

A few decades ago, American Barbers' organisations distinguished several stones.

- Dark colored waterhones, with a grey or clay-like appearance, producing a very fine edge, used with a rubbing stone that created a fine polishing sludge.
- The Belgian oil stone, top-light and mounted on a dark base, or bicolored ones cut from one piece of light rock and adjacent alkali deposit rocks. They cut slightly faster than the water hone.
- Synthetic hones, the oldest of which was the Austrian Swaty, a medium fast cutter, causing rapid overhoning in the hand of the unexperienced.

Present hones are natural or synthetic and can be used dry, with oil or water. Only very fine hones are suitable for razor sharpening; we will not discuss the coarser carborundum and sand stones here, because they are not suitable for razor honing. Fine and very fine natural stones widely available are the Arkansas, Belgian, and Japanese water stones. They are quarried and cut and polished into the preferred size. Most natural stones quarried in the 19th century were good. Particles were densely packed and highly regular. The newer natural stones all carry the risk of containing clustered particles, which form cuboid inclusion bodies that damage the edge; this is a side effect of the dense packing of particles. The figure shows a magnified natural hard Black Arkansas stone with a cuboid inclusion body. This may also be present in all other modern natural stones, the Japanese natural waterstones (Awase Toshi) included. A good natural stone will cost between a few hundred to over thousand dollars. Another problem with natural stones is that the tight bonding of particles prevents rapid release of worn particles. Therefore, used stones lose some of their cutting ability.

The Washita is a coarser type of natural Arkansas stone. They are graded from coarse to fine: Washita, soft Arkansas, hard Arkansas, Black hard Arkansas.

The Belgian stone, also called the Belgian Old Rock, used to be a superb natural hone for razor sharpening. It is used dry, with water or with oil, and has been the standard razor hone for centuries. It is still quarried in Belgium, in the caves around Liege, but due to some earthquakes the production process has been delayed. However, the best stones are already gone, and it is getting increasingly difficult to acquire modern ones

with the same quality as those from the previous century. Therefore, due to irregularities, all present natural stones carry a considerable risk of damaging the edge of the razor. Synthetic stones contain bonded abrasive particles. They are either completely synthetic or reconstituted from crushed natural stones. Some are to be used with water, some with oil, but all natural and synthetic stones might also be used dry. Examples of man made oil stones are silicon carbide and aluminium oxide stones with vitrified bonds. Woodworkers use the coarser ones to do some quick grinding, but for fine honing there are better alternatives. Oil will relatively soon mask the abrasive particles in a synthetic oil stone because of the type of bond. The mix of worn metal, rounded abrasive particles and the oil can stay fixed in place, causing quick glazing.

In contrast, the synthetic waterstones wear rapidly due to loose bonding, permitting easy and regular removal of the remnants with water, exposing a new surface continuously. See the flake like appearance with open structure and loose bond of the Japanese waterstone below. The rapid wearing of a waterstone is generally considered a disadvantage, because narrow cutting tools can create furrows, and with heavy use its life is limited. However, this is relatively unimportant with the delicate use for razor sharpening. Synthetic waterstones came to the West in the seventies.

Synthetic waterstones cut faster than other stones of the same grit number, increasing the risk of overhoning at lower grit numbers, but also permitting the choice of an ultrafine polishing hone that has cutting abilities despite its high grit number. Overhoning is the process of creating a too thin edge, which will break off at first contact, exposing a rough, dull surface. The synthetic waterstones give a much finer finish than would be expected on the basis of their rapid cutting rate. In the fine and ultrafine range (#6000 to #8000), there is no comparable Western synthetic stone. 3M's 0.5 micron chromium oxide on Mylar film cuts exceptionally fast and gives a high polish. It is a #16000 abrasive, which should be glued on glass. Whether one still needs such a fine abrasive with the even finer strop as the last phase, is debated.

Diamond hones are extremely hard, and are available at grits up to #1200, but not in the fine and ultrafine range. They cut very fast. Therefore, they are not suitable for razors. Ceramic stones are sold in very fine grits. However, the bond is so hard that the abrasive particles, which cannot dislodge, get rounded after some time. They should be regularly lapped with a diamond stone to renew the surface.

It remains speculative which type of abrasive compound a synthetic hone should consist of. The most common types are silicon carbide and aluminium oxide. However, chromium oxide may give the edge its ultimate polish. Supported by woodworkers' research, the conclusion seems valid that razors should be honed with the finest available synthetic waterstone, preferably consisting of chromium oxide, or as a good second choice with an antique natural hone. Modern natural hones probably should be avoided, while oil stones will not reach the same amount of polish as a very fine waterstone.

Rubbing stones create an abrasive sludge on the hone. Their usefulness is debated.

Oil and water

The purpose of a honing oil is to prevent glazing, and to flush dislodged abrasive and bonding particles. It should not clog the stone, and it should be a non-drying type. Light mineral oil will do, as will diesel fuel. In stones with an open structure and soft bond, glazing is primarily caused by abrasive particles. Water will flush these particles easily. You can use a water stone with water or dry, but oil will dissolve the resin bonds in a waterstone. In contrast, oil stones can be used both with water and with oil; only hydrofluoric acid will dissolve the vitrified bond of an oil stone. Waterstones produce the best edge in the least amount of time. For polishing, no oil-, ceramic-, or diamond stone can match a waterstone.

A different discussion is whether you should hone dry or wet. Juranitch did research on this and found that liquid dispersed particles blunted the edge while honing. He advocates dry honing, and cleaning the hone with a cloth or water afterwards.

Flattening a hone

It will not be necessary with normal use with straight razors, because the surface is wearing regularly, but if you have an irregular hone you can flatten it. For waterstones you need sandpaper mounted on a glass plate: stones up to #800 need #120 wet- or dry sandpaper; #800 - #1200 stones need #220 paper; #4000 - #6000 stones need #320 - #400 paper. #7000 - #8000 stones: at least #400 paper. You soak the hone and the paper, then stick the paper to the glass with water. Rub circular, until the surface is even. Hollow places will appear darker than the surroundings.

Oil stones are difficult to flatten. You need carborundum powder on glass.

Comparative grit numbers

The #1000 waterstone corresponds to soft white Arkansas oil stones, the #4000 waterstone (fine) to a hard black Arkansas oil stone, and the #6000 (S1 or silver stone), the #7000 Takenoko stone, and the #8000 G1/gold/North Mountain stone have no equivalent among natural stones.

Coarse is defined as up to #800, e.g. for flattening stones.

Medium is #800 to #1200: a sharpening stone for general use; however, it is too coarse to sharpen a razor.

Fine: #4000 - #8000, polishing stones.

Strops

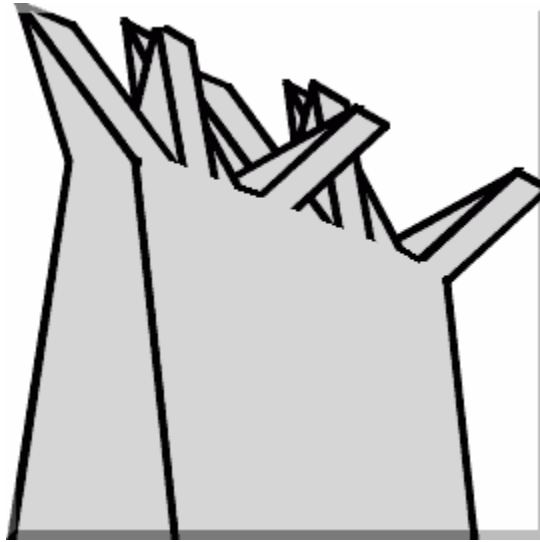

Strops are made of leather on one side, canvas or hemp on the other side. They give the the edge its ultimate polish, and redirect the microserrations after use. The abrasive silica particles in the leather give the strop its unique polishing properties. The purpose of the canvas is not certain. It may be just a coarser polish, or it may serve to increase edge temperature, facilitating the fine polish on the leather. Some barbers only use the canvas side. Juchten, a kind of Russian leather made of younger cows, is better and more durable the smooth horsehide.

In the past, strops required 'breaking in', which is the process of smoothing the strop by rubbing with a glass bottle. Later, pumice, soap and lather were used, reflecting declining craftsmanship. These latter methods destroy the strop, either by increasing its surface coarseness, or by swelling and cracking the leather surface. Strops glued on wood suit straight grind blades, and hanging strops are made for hollow-grind blades. Strop sizes vary. The longest and widest ones facilitate fast and regular stropping with a large contact area between edge and strop.

The available strop-pastes are all coarser than the fine hones. However, a strop should be finer than a hone, not coarser. Therefore, the use of paste is at best irrational, at worst destructive for the edge. Paste colors are not standardized, which makes grading impossible. Black is fine, and red and green are aggressive pastes. White contains chalk, and is meant for use on the canvas or hemp side of strops. Originally, pastes were used to sharpen straight grind blades, such as the Stossmesser. They were never intended to use with hollow grind razors. The use of pastes on strops is therefore wrong. An exception is the yellow fat which serves as a canvas and leather conditioner, causing a slight drag on the edge, which improves polishing.

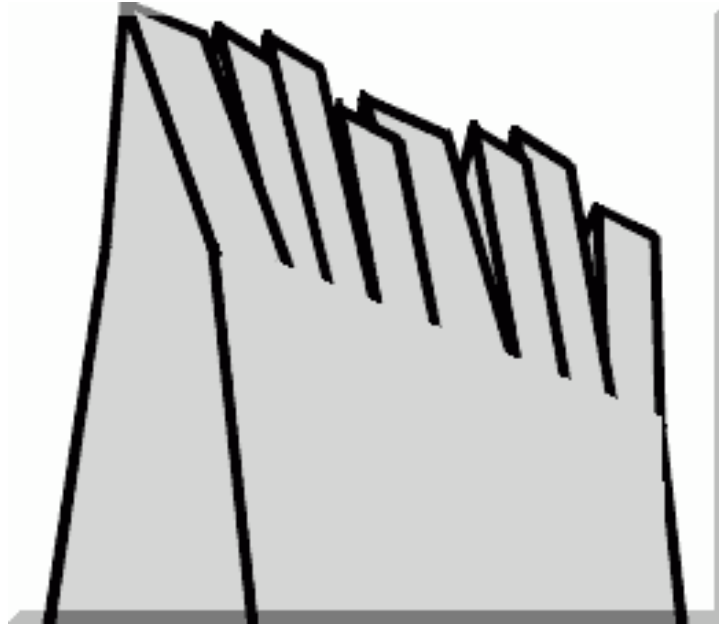

It is not known when to strop. Original publications report that it should be done before shaving only. Manufacturers found that the microserrations align spontaneously after a day rest as the drawings show. The malaligned teeth may break off when they get in contact with the strop. This might cause embedding of metal particles in the strop, decreasing regularity. Probably, after honing, only the leather side should be used, and in all other cases the canvas first.

Honing, introduction

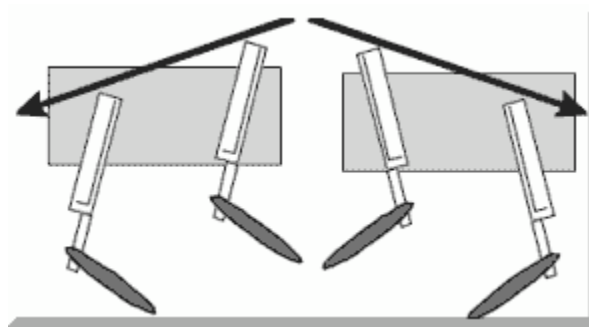

The purpose of honing is to restore the edge. This means that the result must be that the edge sides almost meet at a point again. Given the fact that an edge will always be serrated, the strokes should be diagonally with a constant angle in order to sharpen these teeth, according to the Standard Textbook of Barbering. The paragraph below refers to that book too. The angles also should be equal at strokes in both directions, in order to set the teeth symmetrical.

The razor must be stroked edge-first and diagonally, as the figure shows. The angles and pressure should be equal in both directions, and the pressure should be equal from heel to point, to keep a straight edge from heel to point, and to ensure equal bevels on both sides of the edge.

The razor must be kept perfectly flat while the strokes are made, for if the razor is rocked the least bit, the bevel will become uneven in time, and the result will be a crooked edge instead of one that is perfectly parallel. The edge must never touch the hone in a backward stroke when putting it in position for the second movement.

Before beginning, one should master the technique of turning the razor without turning the wrist. This makes a world of difference in keeping the razor in perfect condition. The first step is to place the razor with the heel on the hone, and back at a slight angle to the right end of the hone, as in the scheme at the right.

Draw the razor diagonally across the hone along the arrow. When this stroke is completed, turn the razor on its back, and at the same time move it up to prepare for the next stroke into the opposite direction. Repeat these movements slowly, attending carefully to the rules given above. If the razor is quite dull, the honing should be first executed with a firm pressure, easing upon the pressure as the razor takes its edge. Experience will guide you in this. Start exercising on a slow hone with an old razor, until the process of honing has become an easy and free muscular act. It is important to acquire correct technique at first, for speed will come naturally with practice.

Geometry

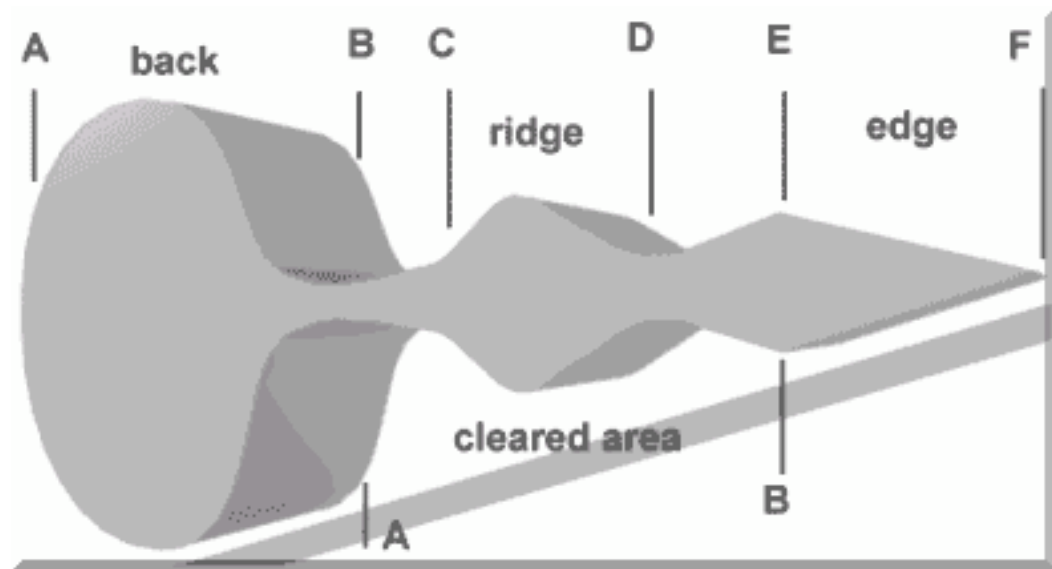

This drawing shows the geometry of hollow grind blade in contact with the hone surface. The lower AB part is filled with metal in a straight grind blade and must be removed before the edge EF can touch the hone. The belly or ridge does not touch the hone. The back conserves cutting edge angle AFA. BC is the hollow grind part, DE the sole.

First stroke



Lay the blade completely flat on the one end of the hone, with the heel within the edges of the hone. Depending on the width of the hone, the point may be outside the hone edges. Push the razor edge forward over the hone, slightly diagonally in the horizontal plane, as was shown in the scheme earlier. Do this as follows.



Last stroke



At the end of the hone, flip the blade over the back as if you roll a pencil between your index finger and thumb without moving the wrist. Start the second stroke, again edge leading, in your direction. Never turn over the edge, this will round off the edge. Keep in mind the scheme with the angles. Repeat this process 5-10 times, or more when the razor is rather dull. As the razor becomes sharp, gradually lighten the pressure and test frequently. This prevents overhoning. An overhoned edge is as bad as a dull one.

How to test a honed edge



When the razor is taking an edge, there will seem to be a suction to the hone. After that, you will start to test whether you honed enough. This is how. Pass the edge over the moistened thumb nail from heel to point. This gives one of the following results.

- The edge passes smoothly and freely without any sensation. This is a blunt edge.
- The edge tends to dig in, but smooth in sensation. This is a keen edge.
- The edge drags quite a bit, and digs in more with a slight grating sensation. This is a coarse edge.
- The edge tends to stick on passing, and gives a harsh, disagreeable, gritty sensation, like a file. This is an overhoned edge. The edge, which is too thin and weak, breaks off on the nail, exposing a rough, dull surface. This can be repaired by passing the edge over a wooden match a few times, or by honing edge-trailing a few times, followed by back-trailing strokes to create the new edge. In general, waterhones prevent overhoning, although modern waterstones cut faster than older ones.
- The edge passes with irregular sensation along the edge. This is an irregular edge. The cause is in irregular honing pressure or angles. Slow down speed and study the process carefully.

When the edge is ready, it is not ready for use. The edge should get a final polish on the strop which gives the razor its specific sharpness. You may need to hone once in 2-12 months depending on many factors.

Stropping, introduction

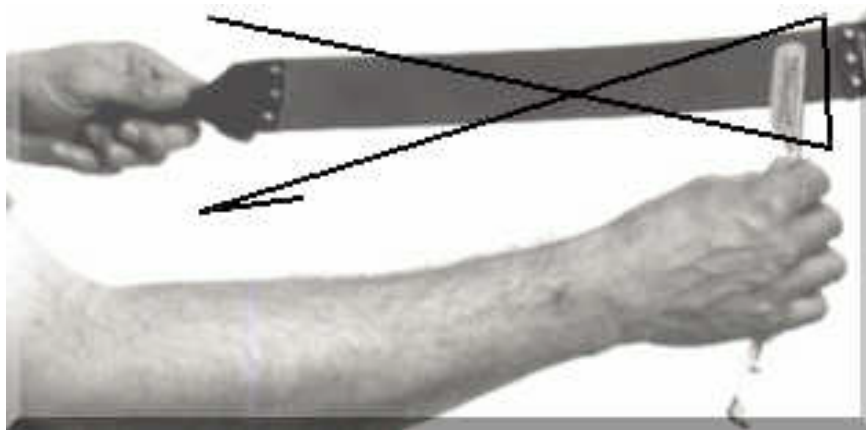

Stropping occurs at exact the same angle as honing. Stropping serves to polish the edge and to align the edge microserrations. After weeks to months, stropping will not give perfect results any more. This is the moment for a few strokes on the hone. Stropping should be done before shaving, as was explained earlier.

The hangings strop must be kept under tension. If it sags, the effective stropping angle increases, and the edge will blunt.

The technique is in the opposite direction than honing: always back leading, in order not to cut the strop. The razor must be kept flat on the leather, the pressure must be a little firm. Hold the razor with the thumb on top of the shank, and roll between the fingers without moving the wrist. The stropping route is indicated in the scheme on the right. In the scheme, the razor just finishes the first stroke from the left to the right.

When the razor is freshly honed, it should be finished on the leather only. After that, use the canvas first, then the leather, each time a razor is stropped.

First stroke



To start, keep the tang between index finger and thumb, and keep them stretched. Place the blade flat on the strop. Strop 5-10 times on the canvas or hemp, 10-20 times on the leather after that. Pull edge-trailing diagonally over the firmly stretched strop, as is shown on the right and in the scheme earlier. Take care that the complete edge has touched the strop in the course of the stroke. Do not press that hard that the edge bends away from the surface.



Last stroke



At the end of the stroke, flip the blade over the edge by rolling the tang between the fingers, and proceed with the second stroke, as is shown on the right. The last four of the series of strokes must be done with almost no pressure.

Testing the stropped edge

A well stropped edge is ready for use. A sharp razor should cut a hanging hair without popping away. Also, if you carefully touch the ball of the thumb with the edge, it should feel a little sticky, and you may hear a high frequent tingling sound. The edge should bite. Do not test on the nail any more after stropping, this will ruin the edge. If the edge does not bite, it is still dull. Do not use a dull razor, because it will cause irritation and bleeding, as you will unconsciously increase the pressure and the angle during usage. Other, less reliable tests are to watch the edge under a bright lamp. It should not reflect. Reflection indicates a surface instead of a point where the edge sides meet.

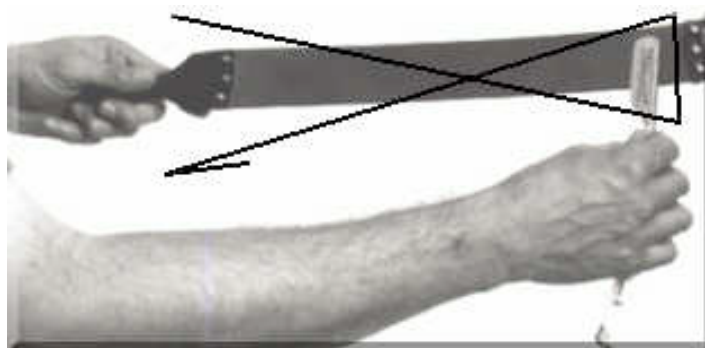

It may be necessary to return to the strop or hone, if the razor does not pass the tests.

Preparation



Do not use the razor if it did not pass tests for sharpness. Remember that the most important cause of failure is an unsharp razor, due to the use of cutting pastes, irregular honing, or bad hones. Hair should be saturated with water, which is the case after two minutes. Use a fat soap and a good bristle, and do not let the lather dry on the face, because then the razor won't work. Apply the lather, then strop the razor. Prepare with not too warm water, and apply. Let it rest a few minutes and use this time to strop. Then lather again. If you use too warm water, it will dry out soon, which makes shaving impossible.

A method suggested in the Standard Textbook of Barbering is the following. Apply the lather to the face with a rotary movement of the brush, with the first two fingers dipping into the bristles for better control. Then proceed to work the lather into the beard, using the cushion tips of the fingers with a light rotary movement. The amount of time required for rubbing the beard depends on its stiffness and density. Remember however, that a well-lathered face is half of a good shave. Lather packs between the hair shafts and helps to keep them erect, giving the razor a better chance to cut through. Now prepare a steam towel by soaking one with warm, not too hot water. Wring it out well and cover the entire surface to be shaved with it. Wait a few minutes, then remove the towel, and lather again. Be sure that the lather is still warm. This method is necessary when the beard is stiff.



Clean the razor under running water or use a finger to sweep the lather away. There is not much to say about brushes here; you may consult the Kent site in the UK mentioned in the references section. After use, dry with a cloth without touching the edge.

The Portuguese Musgo Real Shaving Cream is apparently the best or one of the best shaving creams, made with an exclusive recipe of lanoline, glycerin and coconut oil. It is made since 1920 by Claus & Schweder, founded in 1887, now owned by Acilles Brito. It is the solution for the heavy beard, and it will not dry out. Although it can be used without a brush, the results are much better with a brush. It is sold in tubes which cost about \$8 and last 6 weeks to one year.



The original barbershop aftershaves of the 19th century are still available. The Dominica Bay Rum After Shave is made of alcohol, water and Bay oil. Bay oil is a fragrance containing extracts of the bay plant, *Pimenta Racemosa*, a member of the Myrtle family, which grows throughout Dominica. There are variants with lime and menthol, a Cologne version, and there are other brands producing 'Bay Rum'. However, the basic Dominica version is the original one. Another classic is the Clubman After Shave, which is also available in variants. The basic and original one is the Clubman After Shave. Both Dominica Bay Rum After Shave and Clubman After Shave Lotion come in characteristic

bottles shown here. The reference section has links to on-line resellers of the original brands.

The pictures represent Perret's original and only description of shaving oneself. Pictures you miss were omitted on purpose, as you should improvise there, depending on your motor skills. The route differs from barber's manuals, as these use the point of view of a barber shaving a client, not someone shaving oneself.



Keep the razor as is indicated in the picture, with the handle between middle and ring finger, or with the handle between the little finger and the ring finger. The latter is the original and official method.

This instruction is for right handed people; left handed persons should exchange right and left.



Path

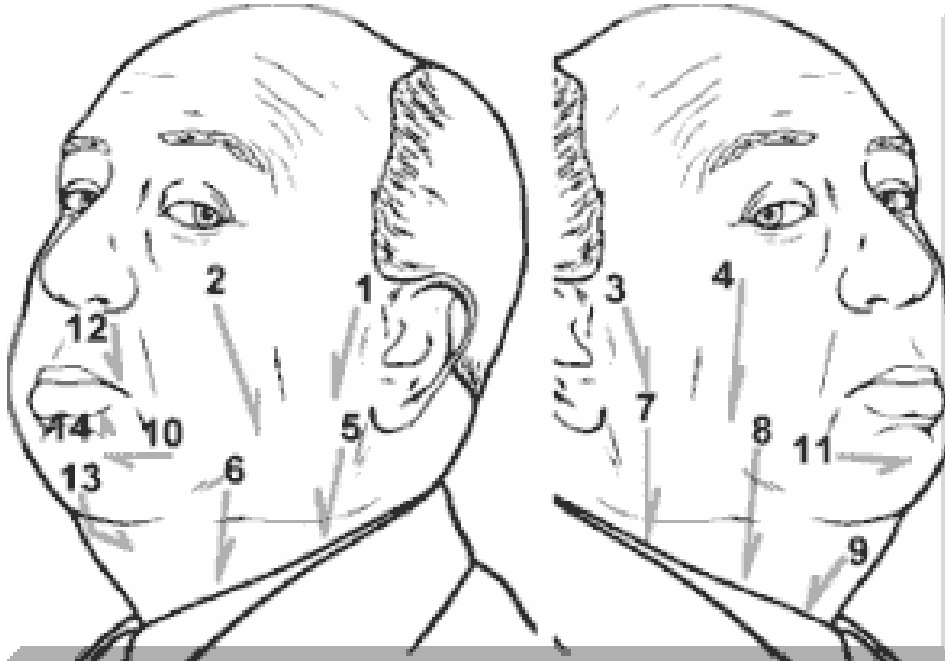

This drawing shows the consecutive stroke paths of the first pass over. Note that 11 is difficult and that originally 10 proceeded towards the right side of the chin. The lower end of strokes 5, 6, 7, 8, 9 and 13 may be done in the opposite direction if the grain is upward. The second over is done in the opposite direction or oblique to it, but never completely against the grain.

Step 1

(PICTURE Missing)

Start at the side of your dominant hand, keeping the skin stretched behind the razor with the other hand, which you put over the head. First, place the blade flat on the skin, then raise the back a little and push the razor forwards, without pressure, and with a slight scything movement. The latter takes advantage of the microserrations on the edge, improving effectiveness. A dull razor will need a much steeper angle to shave. You can choose the cutting angle too great, but not too small. Always follow the razor with the stretching hand, because the point of maximum tension is just behind the razor. Then proceed with the cheek, always stretching. Not stretching is the second most important cause of bleeding, after dullness.



Step 2



Proceed to the left ear and cheek, stretching just behind the back with the other hand. Then shave the right jaw as indicated. Always use the longest strokes possible.



Step 3



Shave from the left cheek to the mouth, and then the chin in the same direction to the right corner of the mouth. It is difficult to shave the chin from the right, so in general this is done completely from left to right, although you are free to improvise. The lower lip should be done as indicated, keeping the blade as flat as possible, to prevent cuts.



Step 4



Put the blade flat against the underside of the nose, and while rotating around the back as its axis, push towards the upper lip. Repeat until the complete upper lip is ready. It is important to keep moving forward while rotating the blade, because you then prevent cuts. The blade touches the skin at a frightening 80 degrees during this Coup de Maître.

Step 5

(PICTURE Missing)

Proceed as indicated. The neck should be stretched between index finger and thumb. The lower part of the neck in the region where the thumb is located in the picture, must be shaved in the opposite direction, when the grain is upwards, which is often the case.



Second over



This is the second shave half against the grain, but never completely against the grain in order to prevent irritation. A second time over is not always necessary. The second time over must be done with warm water, not with lather. If you used a steam towel the first time, use it again for a few minutes, and then apply warm water before shaving. Handle sensitive regions with care.

After the second over, splash the face with cold water, let dry without toweling or towel without rubbing. The cold water will stop any bleeding nicks - if any - immediately, as opposed to those caused by double bladed razors which have a more tearing effect when they loose their sharpness after the first use. This is one of the great advantages of straight razors, although most people only believe that when they start to try out a straight razor themselves.

Apply after shave. Treating toiletries is beyond the scope of this site. In his paper The Art of Old Time Shaving in the September 1999 issue of Knife World, Mr. Jim Shields mentions the old time Clubman and Bay Rum after shaves. Online ordering addresses are included in the references section.

Archives, preface

This section treats the abstracts of Perret's *La Pogonotomie* (1770) and *Das Rasiermesser* (1933). Both books describe in detail how - and how not - straight razors must be cared for, and which are the consequences of wrong treatment and techniques. *Das Rasiermesser* is out of print. *La Pogonotomie* has been translated from Italian into French by Mrs. Lorenzi (see the references section).

Note that the information in the archives may or may not apply to modern razors, depending on the subject. Materials and techniques have undergone an evolution and insights have changed partially. The aim of publishing the abstracts is to put the current knowledge in a historical perspective.

La Pogonotomia I

Preface

It is astonishing that among the millions of books there is not a single brochure that teaches the art of shaving oneself. This is necessary, because it is virtually impossible for a barber to shave more customers without risking infections, and those who shave themselves have healthier skins. This is why I [Perret] invented the 'rasoir a rabot' for novices so they can learn to shave without accidents [Note: rabot is a sort of skin-protective cover on the blade, to be removed when experience increases, not available anymore; it should also serve those who had difficulties in using the non-dominant hand].

Very few persons know how to care for their razor and attributes. Most barbers have excellent tools which they use wrong. There is a critical minimum and maximum for the number of strokes on the hone or strop. The burr resulting from grinding where two planes reach each other is necessary for wood treating tools, but is the enemy of fine edges. The original term 'affiler' means removing the burr.

Razor hones and their different qualities

Not all hones are suitable for honing razors. The Levant, the green hones from Spain, and those from Lorraine and the black ones from England, are too soft and have too large pores that create large, weak teeth on the edge that bend or break when touching the face. Also, large teeth cut hairs at the top and tear at the base alternatively, causing pain.

The only type suitable for razors are the 'Pierres a Rasoirs', found in the caves around Liege, Belgium. They are milk-coloured or yellowish. The former are called Pierres de la Venette. The latter is the Old Rock. Marbled ones or those with veins are sometimes bad. Also, small hard grains may be felt on bad stones, which destroy the edge. Hones should not be too hard with small, dense pores, nor too soft, but better too hard. Too soft makes rough, weak teeth; too hard only takes a few minutes more to hone. If a needle or your nail strikes the stone regular and without much resistance, it is hard enough.

Olive or nut-oil should be used, or water. When a hone is too hard, water can enlarge the pores and make it softer. Therefore, water should not be used on softer stones; it may cause rough edges, which must be corrected by stropping more times and with a little more pressure. Olive oil will clog the hone after seven to eight days causing the edge to slip. The hone must then be cleaned by rubbing with a small piece of a flat pumice stone under water, using the complete length of the hone, for about 10-20 times. The same procedure should be followed when the hone is used and irregular (hard and soft spots) appear. If the hone is too soft, not pumice but another hone of the same type should be used to prevent damage. The surfaces of the rubbing stones should be completely flat and regular.

La Pogonotomia II

About the razor's edge and the art of honing

A razor that works well with a heavy beard may not be effective for a normal one. Excellent razors exist that work well with both types, but this is not more than a compromise resulting from keeping the middle between a strong and a fine edge. The honing technique makes an edge perfect for a specific type of beard. A relatively coarse and strong edge makes the hair fold instead of being cut. A too fine edge 'brakes off' or bends at thick hairs. Inappropriate edges cause hairs to be torn instead of being cut. So, one needs a fine edge for soft beards, and a coarser one for heavy beards. The razor does to a hair what a scythe does to grass but the top of grass is an effective counterweight, which the hair lacks. This imposes special problems on razor care, which are even more difficult to compensate than with the lancet. The lancet has a very soft edge, resulting solely from the technique of honing. The same soft edge is not ideal for the razor, because a hair would glide and pass under the edge and be torn instead of being cut. A razor's edge needs teeth, because its action is not to cut, nor to slash or hack, but to scythe. Therefore, the difficulty is in aligning those teeth perfectly. Also critical is the way the steel has been hardened, ground, and the steel quality. It may cause a razor to hold for two instead of thirty shaves before honing is necessary again. A very good razor will behave as a bad one when honing is not done properly. After grinding, the top of the edge where the two sides meet, is a thin and weak burr, that will bend away under the slightest pressure. The hone must remove the burr. The blade is kept flat on the hone, and with the edge in the direction of movement, oblique strokes are made over the complete length of the hone. The pressure does not exceed the weight of the blade, or sometimes double the weight, but the last three to four strokes are only at the weight of the blade. At the end of the stroke, the tang is turned between index finger and thumb, and the next stroke is in the opposite direction, repeating this about twelve times for the fine razor, about twenty four times for the bigger razor. To judge when you can stop honing, the edge should bite into the skin of the thumb when carefully rubbing it; if not, repeat honing for about four to five strokes (one stroke = back and forth).

One should not give too many strokes, because then a burr forms again, which makes shaving bad. A coarse burr feels like a saw; a fine burr can be missed because sometimes you cannot feel it. In that case, you need a different test. This is done by make a cutting movement from heel to point over the moistened thumb nail. If the movement feels rough with obstacles, there was a burr; if it is smooth, there is no burr. You have to do the cutting movement on your nail twice, because the first time destabilizes any burr, the second time makes the burr fall aside, in such a way that giving 4 or 5 strokes on the hone restores the edge again. The edge is good when it bites into the thumb skin before as well as after having made the cutting movement on the nail twice. This is one of the most constant and consistent observations.

If the razor is a bad one, this technique does not result in removing the burr. In that case, one should hone once with the back forwards and the back raised 1/12 inch - so only the edge rests on the hone; then turn the blade and give one stroke with the edge forward, and again the back raised 1/12 inch; this will result in the fall of the burr. Then give 5 or 6 normal strokes on the hone, back and forth (edge forward). In general, re-grinding on the wheel can de-harden the steel and should be avoided, and never done dry, but it may be sometimes necessary.

La Pogonotomia III

The strop

Even the best razor should be stropped every two or three shaves, especially when only one edge is used - both are used in the ambidexter. The purpose of stropping is to restore the edge of which the teeth are misaligned due to shaving, and to polish the edge. Also, long coarse teeth formed by a too soft hone with large pores are made shorter by stropping. Thus, a strop can compensate somehow but not completely for wrong honing techniques or materials. The continuous rubbing of the edge on the skin causes rounding of the edge when of good quality, and bending when of poor quality. Good leather is calf, buffalo, or beaver. After gluing it on the wood, it is dressed with pumice (dry). Any substance put on the leather should be absolutely free of grains, which might damage the edge. Many substances are used in powder form: stone, pencil, red chalk, hone, pumice, terracotta, and pottery. Pumice and pottery cut so fast that there is a risk of destroying the edge. Good substances are: amaril, le rouge d'Angleterre, vermilion or cinnabre. Rouge d'Angleterre is nothing more than cast iron. The powder is mixed with olive oil or fat. The mixture should be hard and cold before applying it to the strop, then let it dry for two days.

The blade is put flat on the strop, with the tang between index finger and thumb. The blade is pulled over the strop diagonally, back into the direction of movement, so that the complete edge has touched the strop, then the tang is rotated in such a way that the blade flips over the back, then the process repeats 7 times. The edge is good when it bites the skin of the thumb; if not repeat 7 times (1 time = back and forth). The strop should be kept clean and free of dust that can damage the edge. The blade should be clean before stropping. A recommended natural leather is the palm of the hand, especially when covered with some pommade or oil, with the fingers stretched as far as possible backwards in order not to cause injuries.

Some people have a strange experience: they shave until the razor refuses. They then let it rest 6 to eight weeks, strop 4 or five strokes, and are then able to shave again. The reason is seen under the microscope: rust forms in pores on the edge when it is wet; after a few weeks the rust particles drop off while stropping, reducing edge thickness; some more strokes create a new edge, and the razor is restored.

La Pogonotomia IV

Shaving

One should have two razors stand by in case that one might refuse during the procedure, preventing the foam from drying out. Index finger and thumb are placed on the flanks of the tang; the middle finger on the plug connecting handle and tang, the ring finger on the handle, and the little finger on the other side of the handle (handle pointing upwards between middle and little finger). Very important is to keep the skin under tension.

There are rules, described below, where and how to put your fingers and how to keep the razor, but it is necessary to experiment yourself and to find the best position both to shave and to keep the skin under tension. All movements should come from the wrist; the arm kept suspended somehow.

One should keep the razor in the right hand, put your left arm over your head and put your fingers of the left hand just below the right ear, and stretch the skin. Put the razor under the fingers, the back not touching the skin, and shave in a few strokes to the jaw angle. Remember always that the point of maximal tension is just before the fingertips, so replace them with the razor in order to prevent injuries. Then put the fingers on the cheek and shave downwards to the jaw.

Then proceed with the left side. If you want to use the left hand for that, take the razor in the left hand and stretch with the right hand as indicated above. For beginners, ambidexterity is difficult; it is also possible to shave with the dominant hand only, as follows.

After having shaved the right cheek, take the left hand to the left ear, keep the razor below it with the right hand, and shave downwards to the jaw, repeating this in vertical downward strokes until you reach the corner of the mouth. For the moustache, take the nosetip upwards and stretch the upper lip by opening your mouth. Shave downwards, guiding the back by the nose. In that way, the razor rotates along its point-angle axis, which is called 'coup de maitre'. It implies cutting and rotating simultaneously on a stretched upper lip, thus preventing injuries. After having shaved under the nosetip, keep the tip aside and shave the lateral parts of the lip downwards.

The chin is difficult: put the left hand to the left cheek and under the left corner of the mouth and stretch well. Put the blade just before the fingers, and shave from left to right until the chin, making the movement of a scythe. Then replace the point of tension towards where you stopped shaving, somewhere left from the chin, then 'scythe' towards the other side of the chin. Instead of two strokes, you can use three or four, constantly replacing the point of tension to just before the edge, because you cut easily at this site. Then repeat on the right side with the razor again in the right hand. Finish at the chin, using the round point to prevent cutting the lower lip. This is not possible with a square point.

The last part is the neck. Lift the head, stretch at the chin, shave from chin downwards, vertically. Then repeat this more laterally, shaving downwards, first left, then right. Here, also use scything movements. Then put your finger on the chin and shave upwards to the lower lip, using the finger as a guide for the back.

No matter how good a razor is, there are two types of hair, which resist this first shave: coiling hairs and hairs, which grow in different directions. Therefore, a second shave against the grain is always necessary. This procedure is different for every person; find the best grip and study the grain; sometimes it is necessary to shave horizontally from left to right. In general: the procedures of the first shave but then in the opposite direction. Some points are important: Stretch, keep the point of tension just before the edge at all times, and make a scything movement at points where this was indicated

above. Scything means that the direction of cutting changes a little, and the whole edge is used successively during one cutting movement. Use the tongue to stretch the skin when necessary, or pinch the skin between fingers and then pull. Study carefully the direction of growth of the hairs at all places.

The Razor I

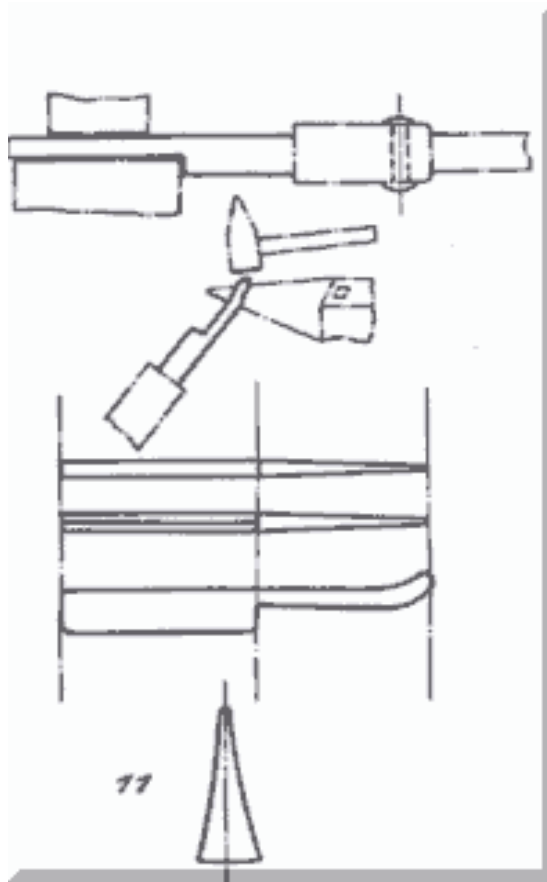

About the book

"Das Rasiermesser" (The razor) has been written in 1939 and was published by Der Messerschmied Verlag. It goes into detail about production techniques, geometry, and it also addresses the increasing competition with safety razors and electric shavers.

Introduction

The razor was originally made of bronze, later iron, and now precious steel. The form is not important for the result. When treated well, it has an almost unlimited life, and the cutting ability can last for years. It is the best tool to shave with, but the care for the edge requires some knowledge and skills, which can be learned easily. For the user, the only additional tool will be the strop, and sometimes a fine hone.

The new generation of shaving tools that arrived since the beginning of the 20th century was neither better, nor easier to use than the straight razor. However, the propaganda machine made people overlook the imperfections of the new inventions. At the same time knowledge about how to use the straight razor was vanishing. On the right and below is a scheme of how razors were forged.

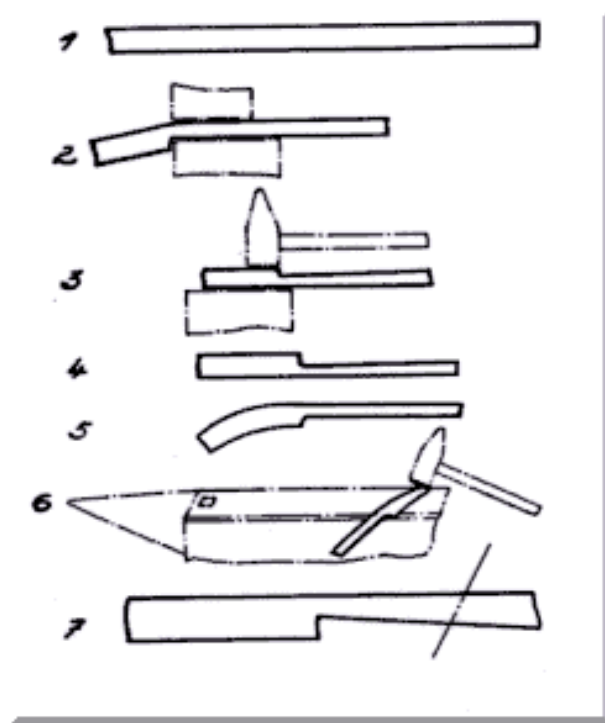

(PICTURE Missing)

The Razor II

The hollow grinding procedure

In principle, it is not important which grade of hollow grind is used, as long as only the cutting edge and the back will touch the hone or strop. In theory, this would already be the case with a grinding wheel of 40 cm diameter, but this is not yet the perfect hollow grind, it is called a 'light' hollow grind or 'flat' grind. The disadvantage is, that in the hand of the layman, including the barber, this 'flat' hollow grind blade rapidly thickens in time after some years of honing. This blade would become dull soon, and could only be resharpened with coarse followed by fine hones. This would take a lot of time and the average user would spoil the blade. Another disadvantage is that these blades are very heavy.

The full (1/1) hollow grind has the opposite effect in the hand of the expert or skilled layman. The edge becomes sharper (the razor gets 'settled'), easier to use, and the slight vibration of the edge caused by the belly increases its effect. Errors will be detected immediately and slight damages to the edge can be repaired easily. The razor is light and easy to use, and can be used for an unlimited period of time without regrinding on the wheel. Shaving is smooth and painless - provided that the user follows some rules.

One of those rules is to conserve the thickness of the back, which should be the blade width divided by 3,5. The hollow grinder divides the blade in two halves: the upper part is hollow, the lower part is a biconvex belly. The biconvex part consists of the edge, the thinning and the belly. The biconcave part of sole, the hollowing, the back and the stabilizing piece. The sole is the thin transition between the belly and the hollow part. The end result is a smooth transition between the parts and parallel shadows when keeping the blade in the light. The shadow moves when rotating the blade, and must keep its width at every place of the blade. During stropping or when rubbing the thumb over the edge, the 1/1 hollow grind blade gives a ringing sound (therefore the designation 'singing razors').

The Razor III

Forms and shapes

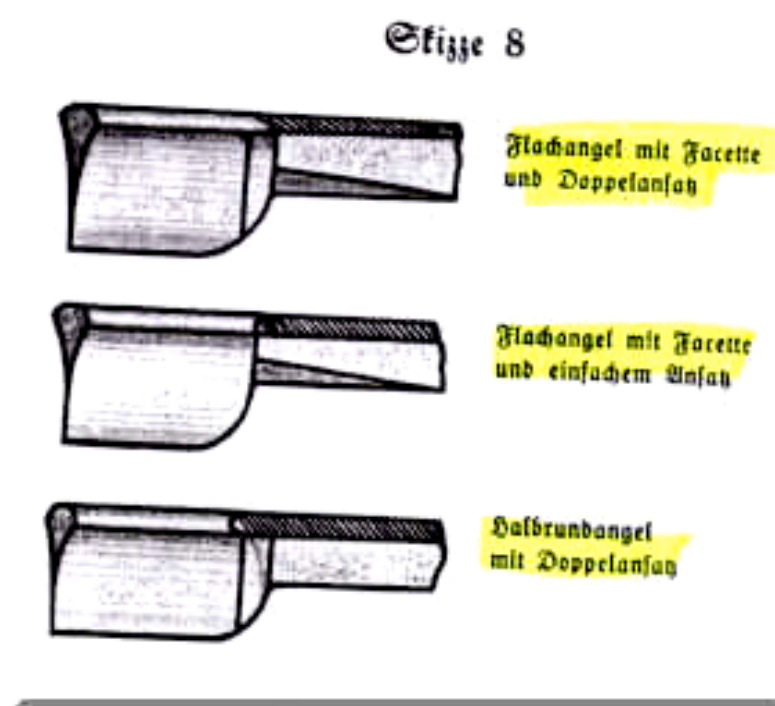

The point can have the following shapes: square with a sharp spike, half round with a round spike, round with a sharp spike, and oblique with a round spike. The spike is the transition between edge and point. The back can be flat, half round, full round, and/or decorated. The tang and stabilizing piece show several different combinations: a flat tang with a double or single stabilizing piece, a half round tang with a double stabilizing piece, a flat tang with a mirror, and a tang with or without stabilizing piece.

Etappe 7

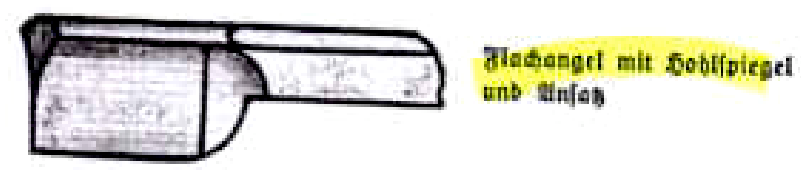
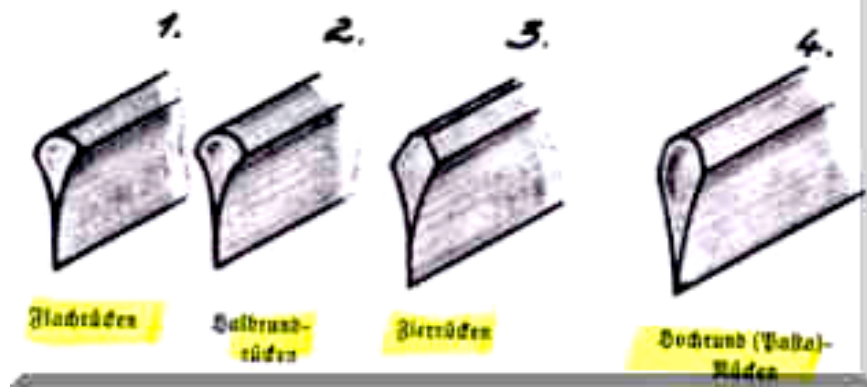

Wahlform

Etappe 6



The Razor IV

The grinding wheels

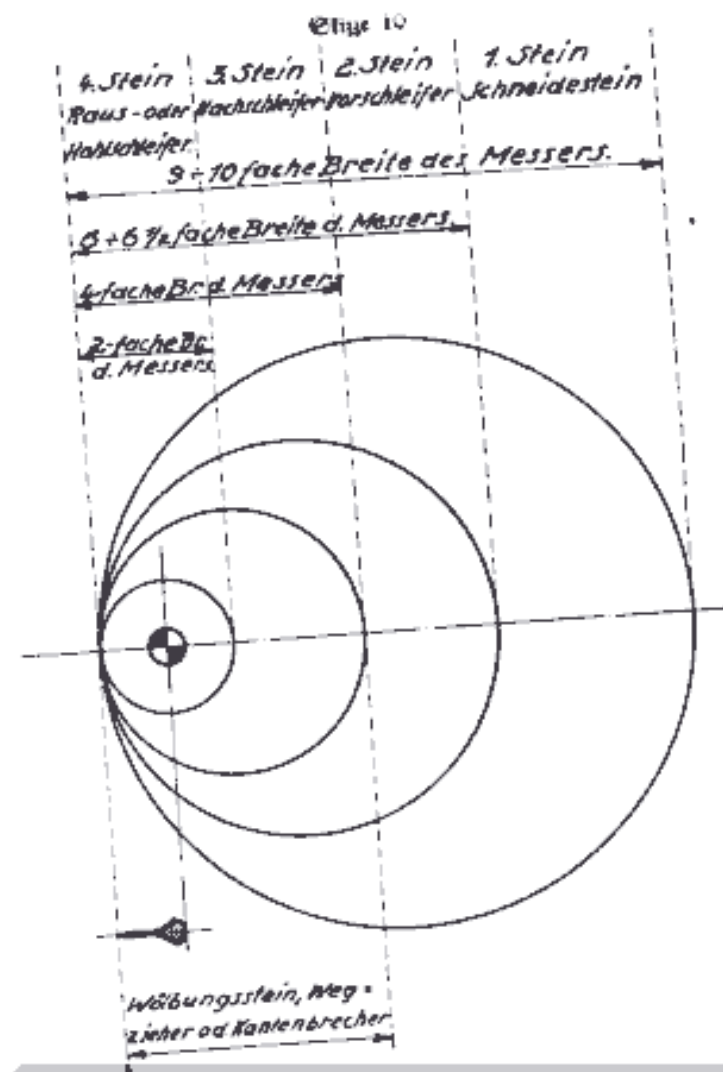

The cutting stones have diameters of 110-120 mm, 140-150 mm, and 170-180 mm for 3/8", 4/8", and 5/8" blades, respectively. Their function is to create the straight edge, the back, and parallel back-edges. The pre-grinders have diameters of 75-80 mm, 95-100 mm, and 105-110 mm, respectively. Their function is to create the concave thinning of the blade between the belly and the edge. This represents the _ hollow grind phase. The post-grinders have diameters of 50-55 mm, 60-65 mm, and 75-80 mm, respectively. Their function is to strengthen the edge and the thin part directly above it, and to create the belly. The hollow grinders have diameters of 26-30 mm; 32-35 mm; and 36-41 mm, respectively, and they have a half round profile. Their function is to dig into the blade. The blade is put on the half round profile, in the length direction of the blade, about 2/3 next to the back.

Rule: the position of the sole determines the grade of hollow grind (1/4, 1/2 or 1/1, for positions directly above the edge to halfway towards the back, respectively - of course, between sole and edge there is always the wall).

After using the cutting stone to create the edge, the edge is honed under a direction of 45 degrees, to strengthen the edge and prevent any further forming of burr. The 45 degree angle is reset later at the sharpening hone.

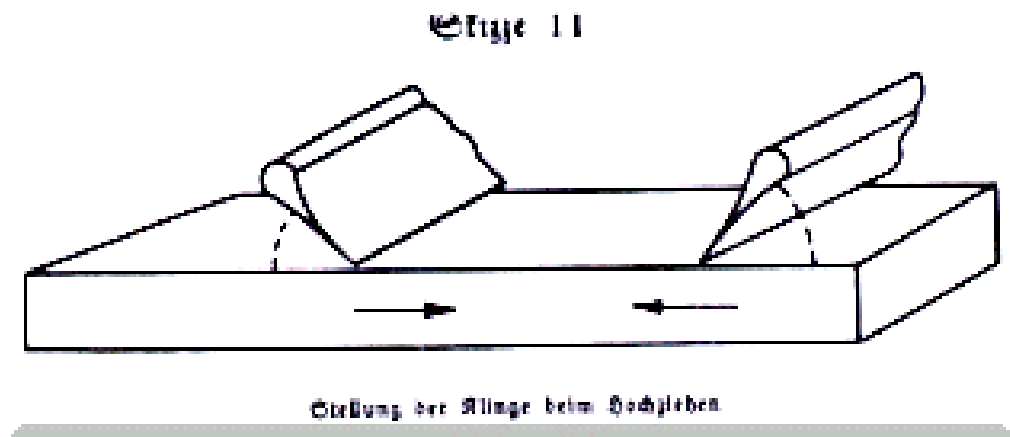

The Razor VI

The strop

The strop gives an extra fine polish to the edge. Stropping is done edge trailing. Flip over the back - never over the edge - and use only as much pressure needed to guarantee that back and edge are both touching the surface.

The Hairtest: take a blond hair between thumb and index finger, and place the edge on the hair 3-4 cm above the thumb. Do not move the blade aside (no slicing movement). It must be cut without bending, and the cut part should not pop away. However, this is just a test; the ultimate test is shaving, which should proceed painless and without needing pressure of the hand.

The pasted strop is just a commercial object, and cannot be advised to the user or expert. The edge is so fine, it needs only honing once a year, and the rest can be done by stropping to polish the edge. Cutting pastes create new edges every time you strop. Coarse pastes cause a rough edge, which does not shave well. Painless shaving is impossible when the edge is not sharp. Only barbers, who damage the edge by shaving many persons a day, need a good cutting paste or a hone to refresh the edge every day. But even then, the cutting pastes are originally meant for French knives, not for hollow ones. Hollow ones form burrs with cutting paste easily. Many barbers stuck to the natural strop without cutting paste. Cutting paste needs special skills and errors are occurring frequently. Also, during shaving the back should be very close to the cheek i.e. with a very small angle, to conserve the edge.

Frequently, customers only start to complain after the razor has been sent in for sharpening. The reason is, that before they shaved with a dull razor, increasing the shaving angle and the pressure, their pain nerves adapting to the pain. After sharpening, they damaged the edge by using the increased pressure and angle they got used to, or worse, by using cutting paste. A burr forms faster the sharper the blade is.

The strop will be very smooth and shining, when the back and point of the blade are not too sharp. The hanging strop is best, because of its length, which should be used completely at every stroke. It should be kept under tension, however, carefully. It is better to have three or four razors you must use alternatively. Warming a cold blade in water can increase comfort.

Many barbers have tried out several tricks with one purpose: to avoid honing. With the so called cutting pastes they believed to have found a suitable method. However, more than ever barbers complain about bad cutting razors, causing them to try out many amateuristic experiments, such as glassplates, ashes, soap, oils, pastes etc, without any success. Even after having used a pasted strop, the unpasted strop is necessary to complete the stropping process. Every barber who wants to use the pasted strop, should have experience with honing first, for 10-15 years.

Then which strop should we use? The best strop is not treated with anything, and serves to 'iron' the edge, make it dry, and somehow clean it. The edge, which microscopically consists of many little parallel steel wires, is maligned by shaving, which is restored by stropping. The surface should better not be fat, because it invites you to use too much pressure. The unprepared smooth strop is better for the fine motor movements of the hand. The leather should not get rough. When you have more experience with the natural, unprepared, smooth strop, a fatty strop can improve the results - can! Also

unprepared, smooth strops can be made a little sticky by putting some fatty paste or crème on it. The other side of the strop is made of some rough fibers, mostly hemp. This side, too, should be shining like a mirror. They serve to strop a few times before using the leather side. The hemp side is also unprepared, or using some fat - no cutting pastes [Note: white contains chalk and is cutting; the only non-cutting paste is the yellow one, or olive oil]

The Razor V

Honing

Grinding creates the rough form and the edge geometry. Honing provides sharpness. A too thin edge will bend, not cut. Honing also gives some strength to the edge. Rule: hard on soft and soft on hard.

There are many lubricants for hones, like oil, soapwater, petroleum, but it is enough when you understand how to hone on a water stone. As a razor is hard, a soft hone is best, but not with a coarse grain. It should have a natural dense surface with fine pores. Thus, it should be a combination of good cutting properties with the finest grit number. The size of a hone should be 300 x 55 mm at least; the surface being completely flat and smooth and saturated with water.

To hone, the tang is kept between index finger and thumb. The turning movement is done by rolling the tang between the fingers, without rotating the hand. Exercise with a pencil. Edge leading, back trailing, both flat on the hone. Strike back and forth about seven times. Use very light pressure, slightly exceeding the weight of the blade. After that, the polishing of the edge starts, preferably with a yellowish waterstone. This total procedure costs about eight minutes. Testing is done by detecting irregularities with the nail probe.

Summary

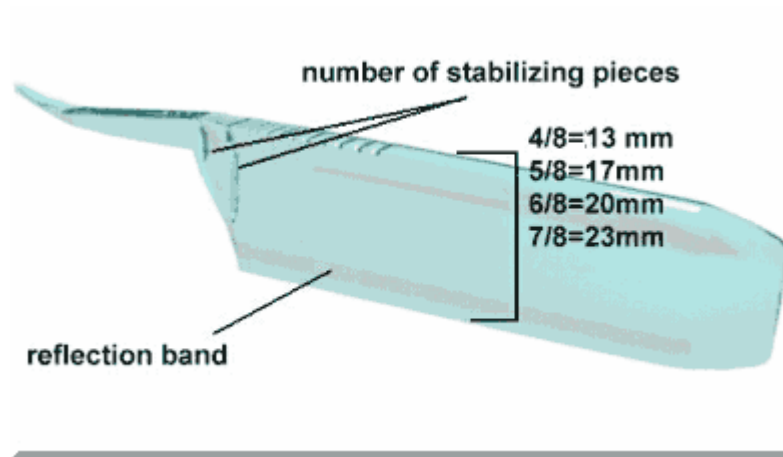

Razor size

In general, the wider ones (6/8 and 7/8") have more torsional stability, making them more suitable for heavy work. As the distance between edge and back is greater than in 4/8 and 5/8" blades, the edge angle remains more constant during its life. Stropping and honing is easier with larger blades, because the plane of contact between blade and medium is wider, hence the position more stable. Compare this with a tripod. The tilt of the blade on any surface is better visible with larger blades. The higher weight - pressure ratio in larger blades gives more stability. The small blades may be of advantage for the beginner; however, the experienced may prefer the large blades. A small blade apparently increases precision, but this is not true.

Form

Spikes have no function. They were removed by professional barbers in the past, because they are dangerous and do not increase precision. Most points are rounded. Further, form is a matter of taste and stability.

Geometry

Full hollow grind has one advantage: it remains sharp with stropping a long time, and it is relatively easy to hone. At the other extreme of the spectrum is the wedge shaped blade. This is excellent for very heavy work, but honing takes a few minutes longer, because you must remove more metal to restore the edge.

Material

Most modern razors are good. You will not have to bother about steel quality, hardening procedures, etc. May be this statement is not true. Stain resistant steel keeps its edge longer than high-carbon steel. May be this is not true either, although there is some evidence. However, the edge of high - carbon steel will show rust holes on electron microscopy within a few minutes after contact with water. Therefore, stainless razors

may be the best choice. Do not use a plated razor, they are bad. The best handles in terms of durability and form-resistance are the resin impregnated wooden ones. Horn and plastic may deform, causing the edge to touch the handle.

Strop

It should be as wide and as long as possible, and made of Juchten. Horsehide is vulnerable and may crack. A hanging strop is preferable because it keeps its form, and can be kept under tension. The other side must be hemp or canvas.

Paste

Use paste to conserve a strop, but not as a lapping compound. It should have no cutting properties. There is only one good paste, which is the yellow one, which may be used on both the canvas and the leather side. Be sure they do not sell you the white paste instead, because it is not the same as yellow. If you doubt, just use a little olive oil, once or twice a year.

Hone

Much has been written about hones, oil, and water, but there is little helpful evidence. However, with an #8000 Chromium Oxide waterstone, such as the Northern Mountain, or an Alu oxid Takenoko, you start with a fresh surface every time. The disadvantage might be rapid wearing when used for carving tools or heavier knives, but this problem does not occur with razors. The #8000 stones are used by Japanese razor sharpeners. Avoid natural stones quarried after 1900 because the inclusion bodies may damage the edge.

Sharpening

Daily stropping and honing 1-4 times a year should suffice. Any action should be symmetrical and constant in pressure, speed, distance, angle, and tilt. Good function is the best test for sharpness, however, there are others to use during the sharpening process: the nail after honing and the thumb after stropping. Honing is done back-trailing, stropping edge-trailing.

Brush

Badger, see the Kent site.

Pivot oil

Normal gun oil, or silicon containing oil.

Original products

Musgo Real, Dominica Bay Rum from Callantilles, and Pinaud's Clubman.

References

Books

1. Roy Ritchie and Ron Stewart. Standard guide to razors, identification and values. Collector books, 1999. ISBN 1-57432-091-2 P.O. Box 3009, Paducah, Kentucky 42002-3009
2. The Razor Anthology. A collection of selected articles about razors, reprinted from monthly issues of Knife World. Knife World Publications, 1995. ISBN 0-940362-17-1 P.O. Box 3395, Knoxville, TN 37927, USA
3. Reichszinnungsverband des Buchsenmacher- und Messerschmiedehandwerks. Das Rasiermesser, sein Werdegang, seine Pflege. Verlag der Messerschmiede, 1939. Out of print.
4. Jean Jacques Perret, La Pogonotomia. Ovverro lárte dímparare a radersi da se. Translated by Edda Chiodini Lorenzi. edizione il Polifilo, Milano. Via Borgonuovo 2, 20100 Milano, Italy.
5. John Juranitch. The Razor Edge Book of Sharpening. Razor Edge Systems Inc., 1985. ISBN 0-9666059-0-X 303 North 17th Avenue east, MN, USA
6. Phillip L. Krumholz. getting to know your straight razors. Published by Phillip L. Krumholz, P.O. Box 4050, Bartonville, IL 61607, USA, 1999. ISBN 0-9620987-5-2
7. Lee L. The complete guide to sharpening. The taunton Press, 1995. ISBN 1561580678
8. Kirby I. Sharpening with waterstones. A perfect edge in 60 seconds. Cambium press, 1998. ISBN 0964399938
9. San Jose Barber College, San Francisco Barber College. Practice and science of standard barbering. Milady publishing corp., Bronx, NY. 1938, Rev 1967. Out of print.
10. Associated Master Barbers of America. Standardized Textbook of Barbering. 3, 1931. Out of print.
11. Moler, A.B. The barbers' manual. 1911, revised 1927. Out of print.

Addresses

Germany

- DOVO Stahlwaren. P.O. Box 190146, D-42701 Solingen. Böcklinstrasse 10, 42719 Solingen. Tel ++49-21-223-001 fax ++49-21-23-13-612 e-mail dovostahlw@aol.com
- <http://web.archive.org/web/20010410031131/http://www.puma-knives.de/>

The Netherlands

- Robijns B.V. Hornweg 196-C, 1432 GS Aalsmeer. Tel ++31-29-73-46-053 fax ++31-29-73-46-212
- <http://web.archive.org/web/20010410031131/http://www.xs4all.nl/~pedewei/index.htm> (Electric Shaver Museum)
- <http://web.archive.org/web/20010410031131/http://www.moosdijk.com/> Van de Moosdijk Collectors Books, Wilhelminaplein 8, 5711 EK Someren, The Netherlands. An excellent specialty bookstore with a vast collection on a wide variety of collector's items

UK

- Brian H. Northcott, 56 Cuckmere Road, Seaford, east Sussex BN25 4 DJ phone ++01-32-38-95-537
- Geo F. Trumper. 20 Jermyn Street, London SW1 6HP

- <http://web.archive.org/web/20010410031131/http://www.kent-brushes.co.uk/bottomframe.htm>

Austria

- Morocutti Knifeshop Vienna.
<http://web.archive.org/web/20010410031131/http://www.knifeshop.com/>

Belgium

- Belgian Old Rock. Ardennes bvba/sprl, Hulststraat 6, B-3600 Genk. phone/fax ++32-89-35-0502 e-mail
<http://web.archive.org/web/20010410031131/http://razorcentral.tripod.com/maurice.celis@skynet.be>. Atelier: Rue Petit-Sart, B-4990 Lierneux. fax ++32-804-182-95 phone ++32-804-18-294
- Le Coticule. Vie nature Miraudon, 42330 St. Medard en Forex. fax ++32-477-941-286 (importeur)

France

- Thiers-Issard/Sabatier. Zone Industrielle de Felet - B.P. 2 - 63306 Thiers Cedex France
- <http://web.archive.org/web/20010410031131/http://www.chambre@coutellerie-thiers.com/>
- For information about where and how to buy Thiers Issard razors in your neighbourhood, write a mail to Mr. David Loft. It will be answered: david.loft@wanadoo.fr

USA

- The Japan Woodworker. 1731 Clement Avenue, Alameda CA 94501 tel ++1-800-537-7820 e-mail support@japanwoodworker.com
<http://web.archive.org/web/20010410031131/http://www.japanwoodworker.com/>
- <http://web.archive.org/web/20010410031131/http://www.tool-shop.com/knives/puma>

Italy

- G. Lorenzi, 9, Via Montenapoleone, 20121 Milano phone ++39-27-602-28-48/76-02-05-93 fax ++39-27-600-33-90

Other Internet sources

general sources

- uniclectica.com
- freedmus.demon.co.uk
- haynesbarberschool.com
- barberschair.com
- the-forum.com
- muzzleblasts.com
- knifecenter.com
- col-conk.com
- omas-antik-haus.com

Musgo, Bay Rum and Clubman

- norvabarber.com
 - vermontcountrystore.com
 - calantilles.com
 - delphis.netgate.net
 - aiibeauty.com
 - acpress.com
 - frenchie.com
 - barclaycrocker.com
 - leisurelan.com
 - stjohnsbayrum.com
-

Colofon

(c) 1998 - 2000 Arthur Boon
De Bult 2
6026 RG Maarheeze
The Netherlands
aeboon@email.com



With Edward Hopper's *Early Sunday Morning* (1929) we conclude our trip back to the future. The information is referenced from collections of past and present expert material and it should suffice to master the art perfectly in a relatively short period of time. You will join the growing number of people who prefer to develop some "Feeling for Snow" above the daily struggle with modern consumer goods. One tip: don't use your razor before it cuts a hanging hair without popping away. If you use a straight razor and want to reduce hazards then don't smoke and drive safely.